

# JT 2127- Flex series of DIMM Socket Test Modules

Multi-channel digital I/O scan module for JTAG test of DIMM connectors

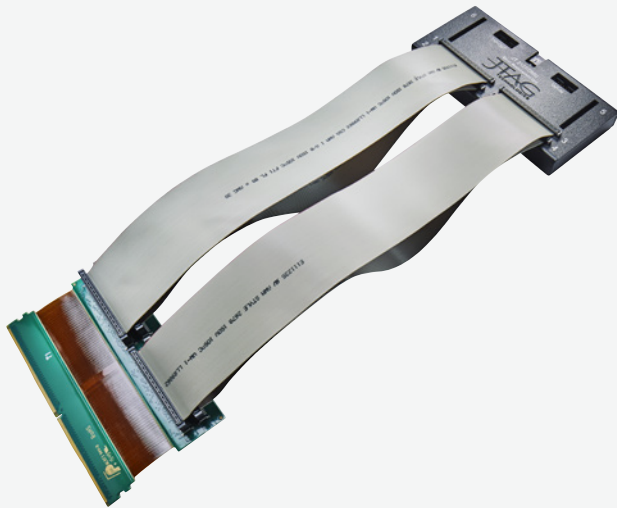

## Key features

- High-density IO module for DIMM Socket testing
- JT 2127/DMU (Digital Master Unit) features 320 DIOS channels
- Measures power rails and tests continuity between socket and PCBA
- Easy connection to UUT via ribbon cables and customised flex adapters
- Flex adapter options include:

- Flex 204 - 3

- Flex 244 - mi3

- Flex 260 - 4

- Flex 288 - 4

JT 2127-Flex is a new family of hardware adapters specifically designed for the testing of a variety of PCB-mounted DIMM & SODIMM sockets (sizes and styles) using a JTAG/boundary-scan controller and supporting software.

### Long-standing challenge

The problem of testing memory sockets has always been troublesome for test and production engineers using JTAG/boundary-scan systems. Even when it is possible to create memory writes/reads from a boundary-scan compliant access device on the UUT (Unit Under Test), the initialisation process may fail leaving you with little diagnostics information. What's more it can still be uncertain whether fault lays with the DIMM module itself or the socket. Using the new JT2127 Flex system from JTAG Technologies you get pin-point diagnostics from a known-good test interface so you can be certain if you socket is soldered correctly.

### Modular System

The JT 2127 Flex system comprises two basic elements. a) a high-speed multi-channel IO module – JT 2127/DMU, and b) a personality adapter for the chosen DIMM type – JT 2127/Flex xxx. The combination of the DMU and Flex adapter allows test signals to be sent to and from the boundary-scan source device on the UUT performing a thorough check for open pins and short circuits.

In addition the voltages on the power pins of the DIMM socket are also measured. Currently supported DIMM types are xxx = 204-3, 244-mi3, 260-4 & 288-4. Due to the modularity of this test system other DIMM format can be supported quickly upon request.

### Software

Software support for test development is provided through JTAG Technologies ProVision developer tool suite which is shipped with a full set of support files for the new system. Completed DIMM socket test applications will also run on the full range of PIP runtime software modules and symphony systems where appropriate.

### Ordering Information

JT 2147/DMU: Socket Test Module digital IO master unit

JT 2127/Flex xxx : Socket Test Flex Adapter

JT 2127/xxx: DMU plus Socket Test Flex Adapter

xxx = 204, 244, 260, 288

# JT 2127- FLEX SERIES OF DIMM SOCKET TEST MODULES

Multi-channel digital I/O scan module for JTAG test of DIMM connectors

## Easy connection

Supplied ribbon cables allow simple connection from the DMU master to the individual test adapters which themselves are equipped with flexi-connect interfaces, making it easy to plug into most DIMM socket topographies.

## Analog Measurements

The JT 2127-Flex system is equipped with analog measurement channels as well as Digital IO (continuity test) channels in order to verify socket supply voltages. These analog channels connect through to the socket using the same flexible personality connector as the digital lines.

### Representative set-up

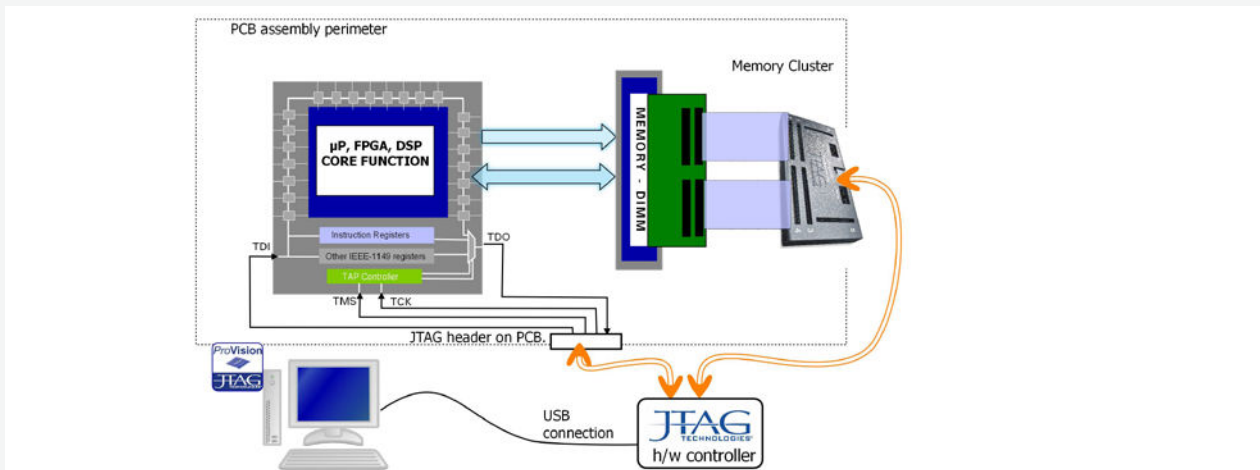

Region or Country	Telephone	E-mail
• North America	Toll free - 877 FOR JTAG Western US - 949 454 9040	info@jtag.com
• Europe and Rest of World	+31 (0)40 295 0870	info@jtag.nl
• Finland	+358 (0)9 4730 2670	finland@jtag.com
• Germany	+49 (0)971 6991064	germany@jtag.com
• Sweden	+46 (0)8 754 6200	sweden@jtag.com
• United Kingdom & Ireland	+44 (0)1234 831212	sales@jtag.co.uk
• China, Malaysia, Singapore, Thailand, Taiwan	+86 (021) 5831 1577	info@jtag.com.cn

2501-JT2127 Flex-E-1000

© The JTAG Technologies logo and other trademarks designed with the symbol "®" are trademarks of JTAG Technologies registered in Europe and/or other countries. JTAG Technologies reserves the right to change design and specifications without notice.

