

Technical Information

Memocheck CYP02D / Memocheck Sim CYP03D

Testing tools for analysis measuring points

Simulation of sensors with Memosens Technology



Application

- Chemicals and process engineering
- Food, pharmaceutical industry and biotechnology
- Water and wastewater treatment
- Hazardous areas

Your benefits

- Increased plant safety thanks to complete sensor and error simulation
- Easy, quick and reliable sensor simulation with user-definable measured values for CYP03D and fixed values for CYP02D
- Error simulation
- Verification of all parameters: pH (glass and ISFET), ORP, conductivity (conductive and toroidal), dissolved oxygen (amperometric and optical), chlorine, turbidity and nitrate
- High degree of flexibility when commissioning the measuring point
- Utmost reliability owing to Memosens Technology:
 - No contact corrosion
 - Completely watertight
 - No interference from external potential thanks to galvanic isolation of simulator and transmitter

Function and system design

Simulation setup in non-hazardous areas

Sensor simulation in a complete measuring system consists of:

- Memocheck CYP02D or Memocheck Sim CYP03D
- Transmitter with Memosens Technology, e. g. Liquiline M CM42 or Liquiline CM44x
- Memosens data cable CYK10

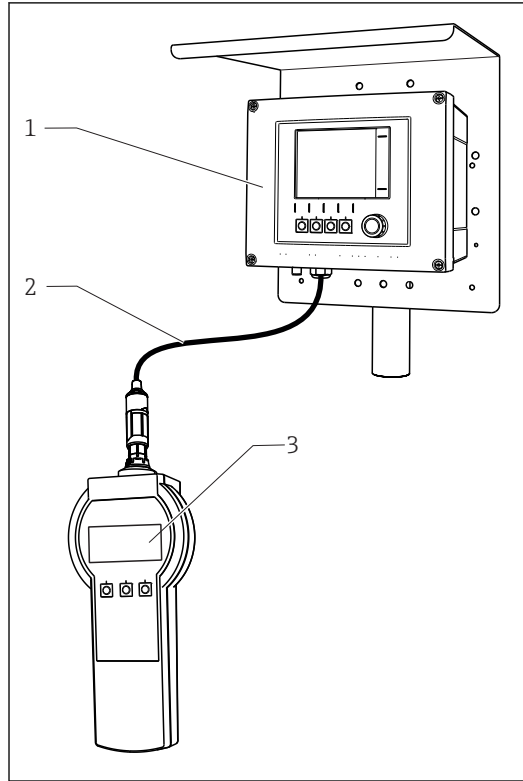

A0025995

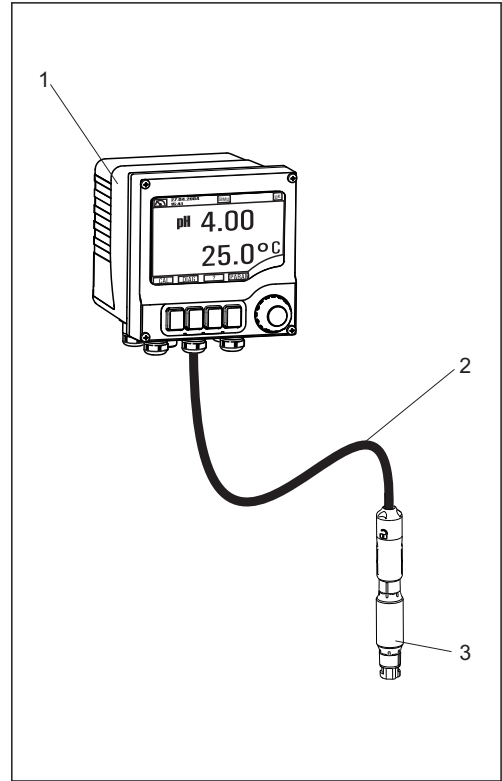

A0025994

1 Measuring system with Memocheck Sim CYP03D

- 1 Transmitter Liquiline CM44x
- 2 Memosens data cable CYK10
- 3 Memocheck Sim CYP03D

2 Measuring system with Memocheck CYP02D

- 1 Liquiline M CM42 transmitter
- 2 Memosens data cable CYK10
- 3 Memocheck CYP02D

Simulation setup in hazardous areas

Sensor simulation in a complete measuring system consists of:

- Memocheck Sim CYP03D
- Transmitter with Memosens Technology and Ex approval, e. g. Liquiline M CM42
- Memosens data cable CYK10

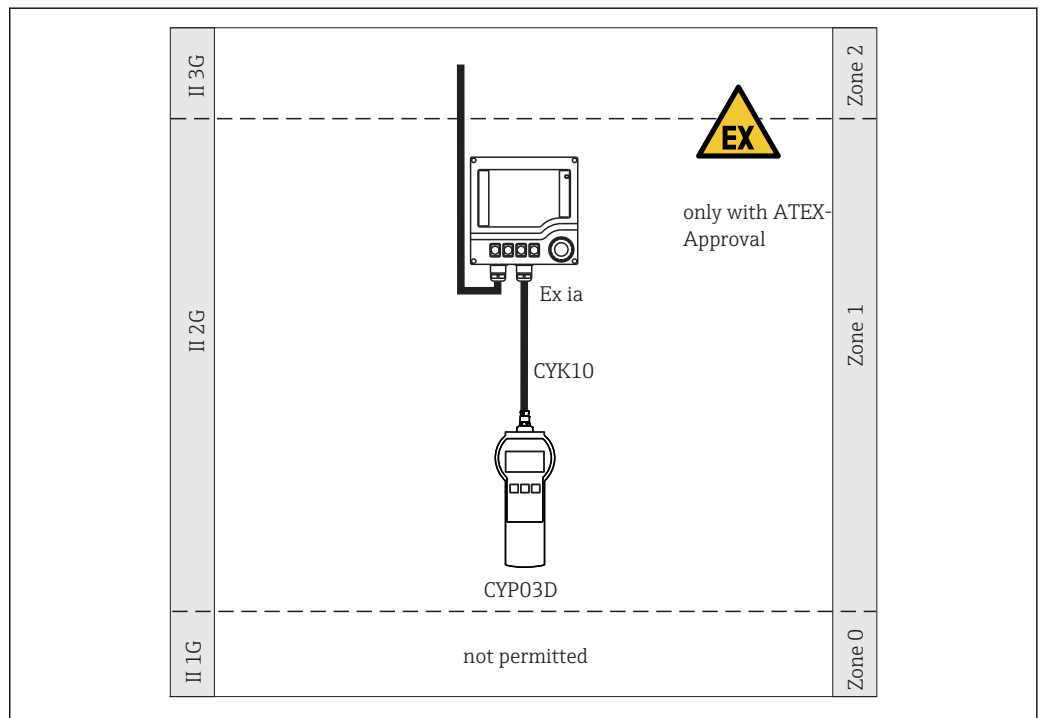

3 Operation in hazardous areas

Performance characteristics

Memocheck CYP02D simulation values

Memocheck CYP02D consists of two interconnected sensor plug-in heads which are independent of one another, and which each supply one specific parameter. You can simulate the following values depending on your order:

Simulation values output for pH glass and pH ISFET

	Fixed simulation value	Temperature
pH glass	4	25 °C (77 °F)
pH ISFET	7	60 °C (140 °F)

Simulation values output for pH glass and pH glass

	Fixed simulation value	Temperature
pH glass	4	25 °C (77 °F)
pH glass	7	60 °C (140 °F)

Simulation values output for pH glass and ORP

	Fixed simulation value	Temperature
pH glass	4	25 °C (77 °F)
ORP potential	750 mV	90 °C (194 °F)

Simulation values output for pH glass and oxygen

	Fixed simulation value	Temperature
pH glass	4	25 °C (77 °F)
Oxygen	60 nA ¹⁾	60 °C (140 °F)

1) Sensor current

Simulation values output for pH glass and conductive measurement of conductivity

	Fixed simulation value	Temperature
pH glass	4	25 °C (77 °F)
Conductivity	20 µS/cm	60 °C (140 °F)

Simulation values output for pH glass and chlorine

	Fixed simulation value	Temperature
pH glass	4	25 °C (77 °F)
Chlorine	60 nA ¹⁾	25 °C (77 °F)

1) Sensor current

The data listed above are displayed on the transmitters.

Memocheck CYP02D is maintenance-free.

Memocheck Sim CYP03D simulation values

With the Memocheck Sim CYP03D you can simulate the following data:

- Simulation values
 - Main values
 - Raw values
 - Temperature
- Parameter
 - pH glass (**pH glass**)
 - pH glass, SIL sensor (**pH glass SIL**)
 - pH ISFET (**pH Isfet**)
 - ORP (**ORP**)
 - pH + ORP combined sensor (**pH + ORP**)
 - Conductivity conductive (**Cond c**)
 - conductivity, conductive, 4-pin (**Cond c 4-pol**)
 - conductivity, inductive (**Cond i**)
 - oxygen, amperometric (**Oxygen (amp.)**)
 - Oxygen, optical, Memosens (**Oxygen (opt.Memo.)**)
 - Oxygen, optical, fixed cable (**Oxy. (opt.fixed)**)
 - Chlorine (**Chlorine**)
 - Turbidity (**Turbidity**)
 - Nitrate (**Nitrate**)
 - SAC (**SAC**)
- The main simulation values can be selected as required within the context of the sensor specification values
- Repeated ramp with any increment
- Error, e. g. glass breakage, alarm and warning
- Calibration values

You can freely configure all the values so that they match your process. The data listed above are displayed on the transmitters.

The Memocheck Sim CYP03D can, with the quality or calibration certificate, also be used as a qualification tool for your measuring point.

The quality and calibration certificates can be renewed:

For such services, you will need to return Memocheck Sim CYP03D to Endress+Hauser.

In the case of **requalification**, the device is tested fully and a new quality certificate is issued.

In the case of **recalibration**, in addition to requalification the device is also incorporated into a calibration procedure. A quality certificate and a certificate of calibration are issued. The recommended testing interval is 1 year.

Environment

Ambient temperature range	<p>Memocheck CYP02D -15 to 70 °C (5 to 158 °F)</p> <p>Memocheck Sim CYP03D -20 to 50 °C (-4 to 120 °F)</p>
----------------------------------	--

Storage temperature	<p>Memocheck CYP02D -15 to 70 °C (5 to 158 °F)</p> <p>Memocheck Sim CYP03D -20 to 55 °C (-4 to 130 °F)</p>
----------------------------	--

Degree of protection	<p>Memocheck CYP02D IP65</p> <p>Memocheck Sim CYP03D IP55</p>
-----------------------------	---

**Electromagnetic
compatibility**

Interference emission and interference immunity as per EN 61326-1:2013, Class A for Industry

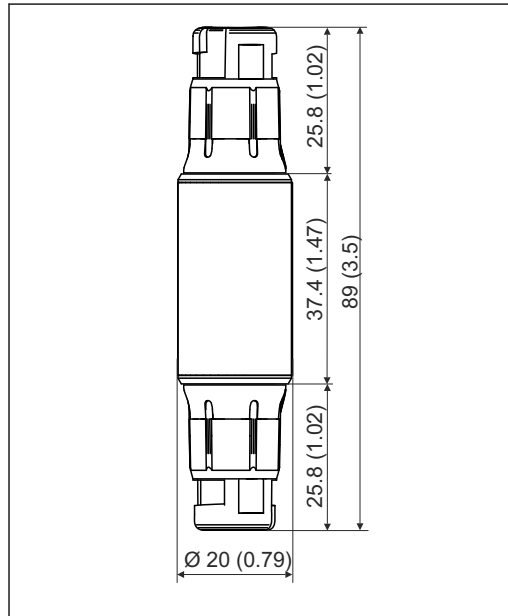
Mechanical construction**Dimensions**

A0026004

4 Memocheck CYP02D

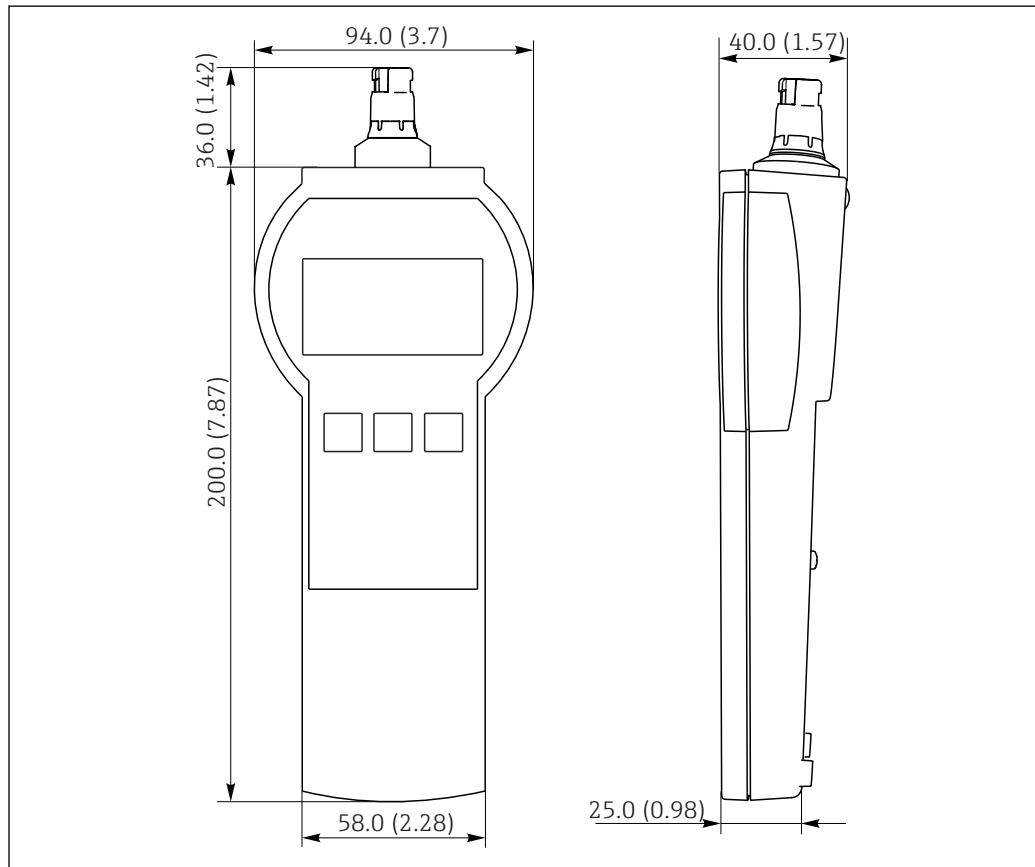

A0026005

5 Memocheck Sim CYP03D

All dimensions in mm (in)

Weight (CYP03D only, incl. batteries) 0.3 kg (0.7 lbs)

Materials

Memocheck CYP02D:
 White plastic: PET
 Blue plastic: PPS GF 40

Memocheck Sim CYP03D:
 Housing: ABS (UL 94 HB)

Batteries

No batteries are required for the Memocheck CYP02D.

For the Memocheck Sim CYP03D, use only the following battery types, as only these are covered by the Ex approval:

- Energizer, EN91 (AA, 1.5 V, LR6 as per IEC), x 3
- Battery storage temperature: -20 to 35 °C (-4 to 95 °F)

Certificates and approvals

CE mark

The product meets the requirements of the harmonized European standards. As such, it complies with the legal specifications of the EU directives. The manufacturer confirms successful testing of the product by affixing to it the **CE** mark.

Ex approvals

Memocheck Plus CYP02D

- ATEX/IECEX II 2G Ex ia IIC T6 Gb
- FM/CSA IS NI Cl.I Div.1&2, Group A-D

Memocheck Sim CYP03D

- ATEX II 2G Ex ia IIC T4 Gb
- IECEX Ex ia IIC T4 Gb
- CSA IS NI Cl. I, Div. 1&2, Group A-D

Ordering information

Product pagewww.endress.com/cyp02dwww.endress.com/cyp03d

Product Configurator

On the product page there is a **Configure** button to the right of the product image.

1. Click this button.
 - ↳ The Configurator opens in a separate window.
2. Select all the options to configure the device in line with your requirements.
 - ↳ In this way, you receive a valid and complete order code for the device.
3. Export the order code as a PDF or Excel file. To do so, click the appropriate button on the right above the selection window.

 For many products you also have the option of downloading CAD or 2D drawings of the selected product version. Click the **CAD** tab for this and select the desired file type using picklists.

Scope of delivery**Memocheck Plus CYP02D**

- 1 Memocheck CYP02D with 2 plug-in heads
- 1 Operating Instructions (de + en)

Memocheck Sim CYP03D

- Memocheck Sim CYP03D
- Operating Instructions
- 1 quality certificate as ordered
- Cable as per order (optional)
- Case to store CYP03D and cable (optional)
- Certificate of calibration (optional)

Accessories

The following are the most important accessories available at the time this documentation was issued.

- ▶ For accessories not listed here, please contact your Service or Sales Center.

Memosens data cable

Order No.	Memosens data cable CYK10 (optional)
71128718	CYK10-A032 + adapter, cable ends; Non-Ex
71128721	CYK10-G032 + adapter; only for CYP03D, Ex

For the Memocheck CYP02D, you can use the Memosens data cable CYK10 belonging to the measuring point.

To connect the Memocheck Sim CYP03D to transmitters with M12 sockets and Pg couplings, you require the Memosens data cable CYK10 provided. The cable is always supplied with an adapter piece so that it fits both M12 sockets and Pg couplings. If you wish to simulate fixed cable sensors (turbidity, nitrate, toroidal conductivity, oxygen optical) with the Memocheck Sim CYP03D, you need this cable. When using sensors with an inductive Memosens plug-in head (pH/ORP, oxygen, conductive conductivity, chlorine), the appropriate cable is already included in the measuring point.

Storage case

Order No.	Case for Memocheck Sim CYP03D
71183327	Ex

In the hazardous area, the Memocheck simulator case should only be opened to remove or put back the Memocheck simulator. When opened, the case should never be exposed to process-related intensive electrostatic charges.



www.addresses.endress.com
