

Technical Information

iTHERM TT131

Welded thermowell for a range of industrial applications



Thermowell for RTD and TC assemblies, specially designed for use in industrial applications, particularly in the chemical, oil & gas and power & energy industries

Application

- Protects the temperature sensor against physical and chemical stress
- Highly robust design for challenging process conditions
- Pressure range up to 100 bar (1 450 psi)
- For use in pipes, vessels or tanks
- Easier maintenance and recalibration of the measuring point (sensor can be replaced without interrupting the process)

Your benefits

- Modular configuration according to DIN 43772
- iTHERM QuickNeck: cost and time savings thanks to simple, tool-free recalibration of the insert used
- Extension, immersion length and total length can be chosen according to process requirements
- Wide range of dimensions, materials and process connections available
- Specially designed tip for fast response times

Table of contents

Function and system design	3
Equipment architecture	3
Modular design	3
Installation	3
Mounting location	3
Orientation	3
Installation instructions	3
Process	4
Process temperature range	4
Process pressure range	4
Medium - state of aggregation	6
Mechanical construction	7
Design, dimensions	7
Weight	10
Material	10
Process connections	12
Surface roughness	21
Certificates and approvals	22
CRN approval	22
Other standards and guidelines	22
Service	22
Material certification	22
Thermowell testing	22
Ordering information	23
Accessories	23
Device-specific accessories	24
Service-specific accessories	24
Documentation	25

Function and system design

Equipment architecture

The thermowells are designed according to DIN 43772 and can therefore guarantee a good level of resistance to the most typical and common industrial processes. The thermowell comprises a pipe with a diameter of 9, 11, 12, 14 or 16 mm, or ¼" or ½" pipe. The tip of the thermowell can be straight, tapered or reduced (stepped). A PTFE sheath can be supplied for thermowells with straight tip, and a tantalum sheath in straight or tapered versions. The thermowells can be fitted to a pipe or vessel in the system using a selection of commonly used flanged process connection, thread or compression fittings.

Modular design

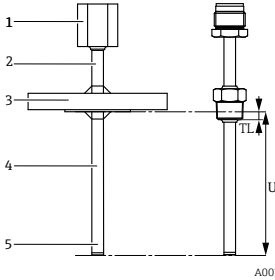
Design	Options
	1: Thermometer connection
	2: Lagging
	3: Process connection
	4: Immersion part
	5: Thermowell tip

Installation

Mounting location

The thermowells can be installed in pipelines, tanks or vessels.

Orientation

No restrictions. However, self-draining in the process should be guaranteed depending on the application.

Installation instructions

The immersion length of the thermometer can influence the accuracy. If the immersion length is too short, this can lead to measurement errors caused by heat conduction through the process connection. If installing in a pipe, the immersion length should ideally correspond to half of the pipe diameter. Although the installation position may vary according to requirements, the measuring element must be completely exposed to the medium and must not be shielded by the nozzle. In pipes with a small diameter, a pipe expander can be mounted around the measuring point to ensure a sufficient immersion length.

Installation possibilities: Pipes, tanks or other plant components

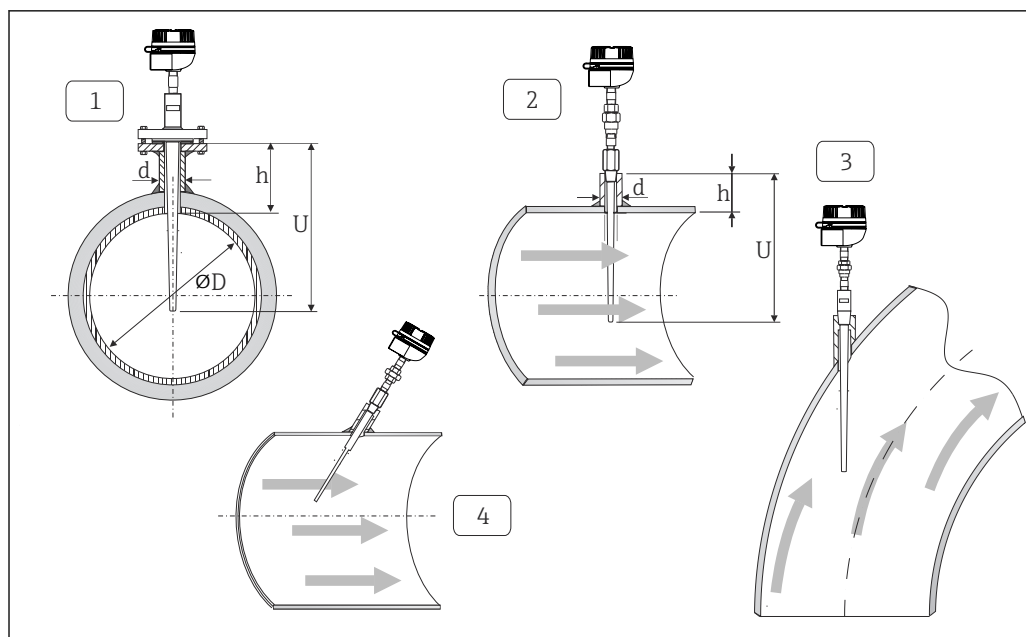

A0010222

1 Installation examples

1 - 2 In pipes with a small cross-section, the sensor tip should reach or extend slightly past the center axis of the pipe ($=U$).

3 - 4 Slanted orientation.

i In the case of pipes with a small nominal diameter, it is advisable for the tip of the thermometer to project well into the process so that it extends past the pipe axis. Another possibility is to install the thermometer at an angle (4). When determining the immersion length or installation depth, all the parameters of the thermometer and of the medium to be measured must be taken into account (e.g. flow velocity, process pressure).

The use of iTHERM QuickSens inserts is recommended for immersion lengths $U < 70$ mm (27.6 in).

i The counterpieces for the process connections and the seals or sealing rings are not included in the scope of supply for the thermometer.

Process

Process temperature range

Depends on the type of thermowell and material used, maximum -200 to $+1100$ °C (-328 to $+2012$ °F).

Process pressure range

The maximum possible process pressure depends on various influencing factors, such as the design, process connection and process temperature. For information on the maximum possible process pressures for the individual process connections, see the 'Process connection' section.

i It is possible to check the mechanical loading capacity as a function of the installation and process conditions online using the Sizing Thermowell calculation tool in the Endress+Hauser Applicator software. <https://portal.endress.com/webapp/applicator>

Permitted flow velocity depending on the immersion length

The highest flow velocity tolerated by the thermometer diminishes with increasing sensor immersion length exposed to the flowing fluid. In addition it is dependent on the diameter of both the thermometer tip and thermowell, on the type of measuring medium, the process temperature and the process pressure. The following figures exemplify the maximum permitted flow velocities in water and superheated steam at a process pressure of 50 bar (725.2 psi).

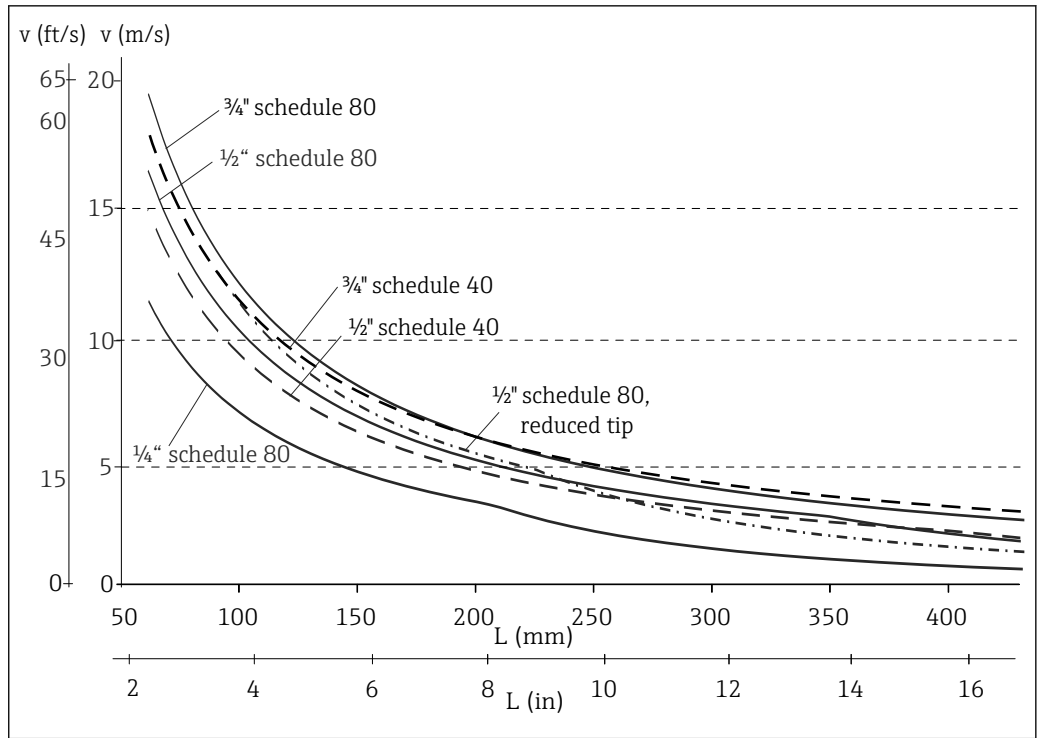

A0017374

2 Permitted flow velocities with different thermometer diameters in the process medium water at $T = 50\text{ °C}$ (122 °F)

L Unsupported immersion length of the thermowell, material 1.4401 (316)
 v Flow velocity

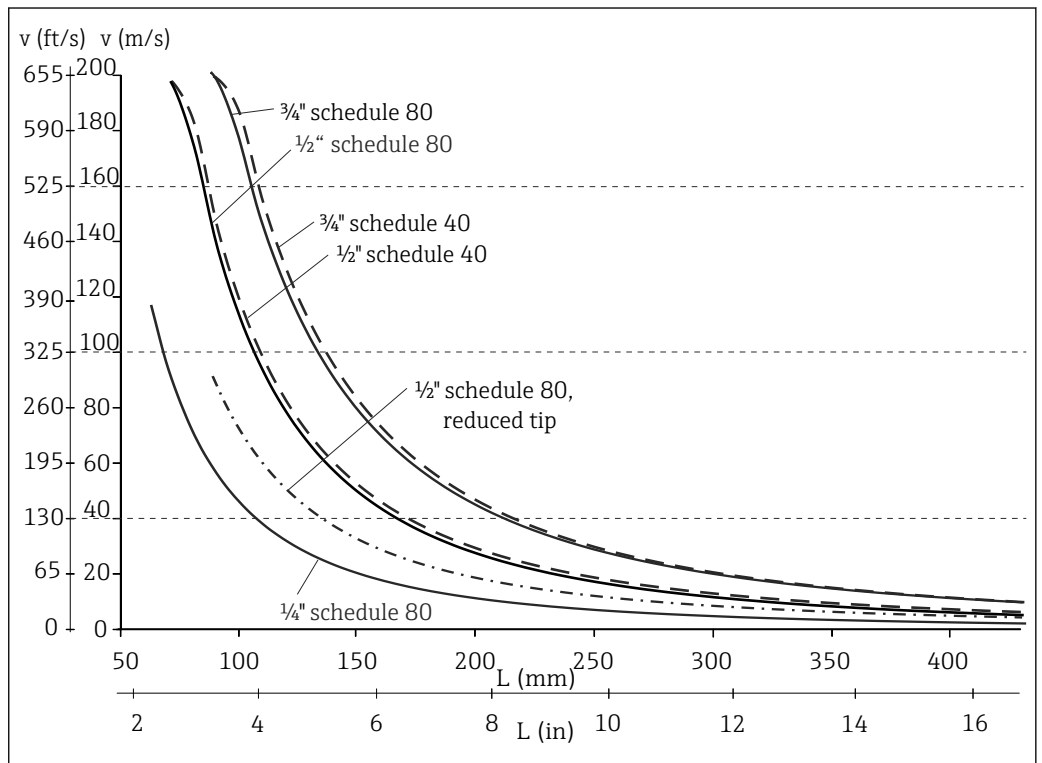

A0017438

3 Permitted flow velocities with different thermometer diameters in the process medium superheated steam at $T = 400\text{ °C}$ (752 °F)

L Unsupported immersion length of the thermowell, material 1.4401 (316)
 v Flow velocity

Permitted flow velocity depending on the immersion length and process medium

The highest flow velocity tolerated by the thermometer diminishes with increasing insert immersion length exposed to the flowing fluid. The flow velocity is also dependent on the diameter of the thermometer tip, the type of medium being measured, the process temperature and the process pressure. The following figures exemplify the maximum permitted flow velocities in water and superheated steam at a process pressure of 50 bar (725 psi).

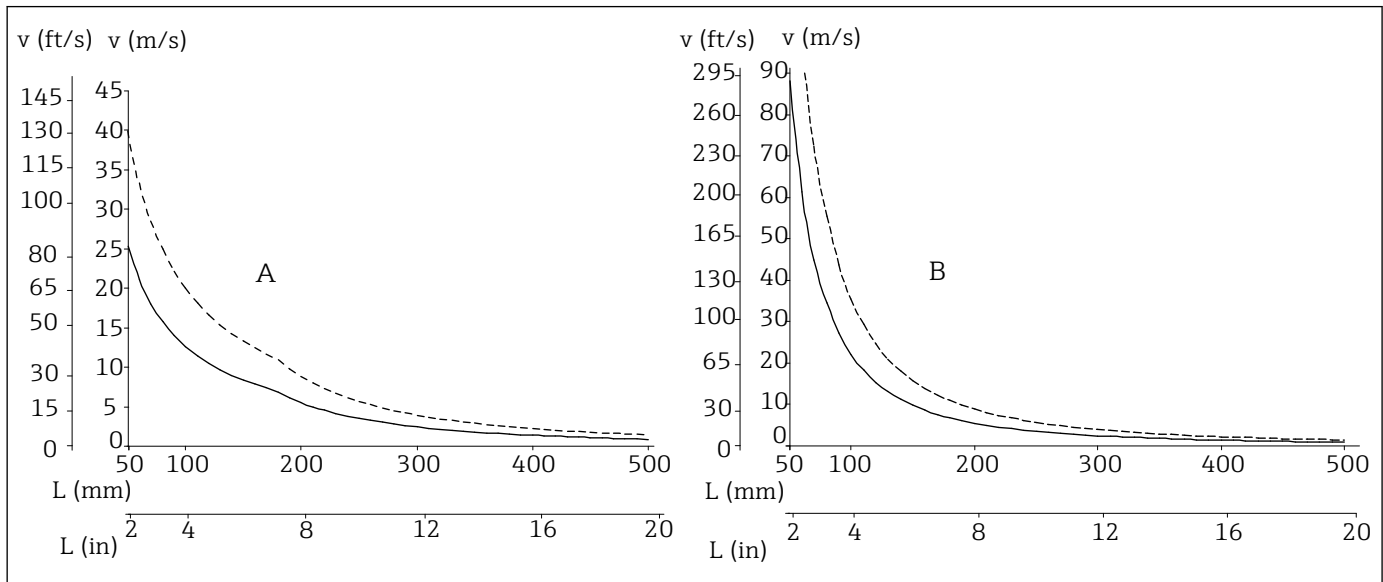

A0008605

4 Maximum flow velocity with thermowell diameter 9 mm (0.35 in) (—) or 12 mm (0.47 in) (----)
 A Medium: water at $T = 50\text{ }^{\circ}\text{C}$ (122 $^{\circ}\text{F}$)
 B Medium: superheated steam at $T = 400\text{ }^{\circ}\text{C}$ (752 $^{\circ}\text{F}$)
 L Immersion length
 v Flow velocity

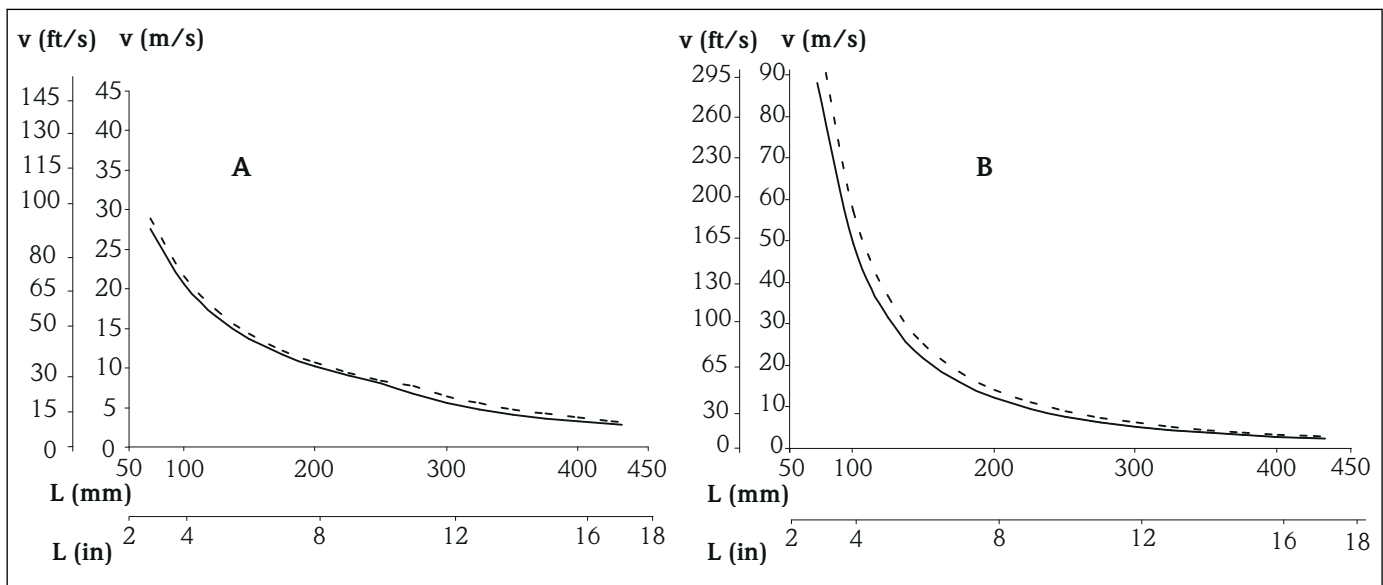

A0017169

5 Maximum flow velocity with thermowell diameter 14 mm (0.55 in) (—) or 15 mm (0.6 in) (----)
 A Medium: water at $T = 50\text{ }^{\circ}\text{C}$ (122 $^{\circ}\text{F}$)
 B Medium: superheated steam at $T = 400\text{ }^{\circ}\text{C}$ (752 $^{\circ}\text{F}$)
 L Immersion length
 v Flow velocity

Medium - state of aggregation

Gaseous or liquid (also with high viscosity, e.g. yogurt).

Mechanical construction

Design, dimensions

All dimensions in mm (in). The design of the thermometer depends on the thermowell version: The type of lagging is a crucial factor in the construction.

Thermowell diameter:

Diameter	Tip shape	Material
9 mm x 1.25 mm	<ul style="list-style-type: none"> ▪ Straight ▪ Reduced ▪ Tapered 	<ul style="list-style-type: none"> ▪ 316L ▪ 316Ti ▪ AlloyC276 ▪ Alloy600
11 mm x 2 mm	<ul style="list-style-type: none"> ▪ Straight ▪ Reduced 	<ul style="list-style-type: none"> ▪ 316L ▪ 316Ti ▪ AlloyC276 ▪ Alloy600
12 mm x 2.5 mm	<ul style="list-style-type: none"> ▪ Straight ▪ Tapered 	<ul style="list-style-type: none"> ▪ 316Ti ▪ 321
14 mm x 2 mm	Straight	316L
16 mm x 3.5 mm	Straight	316L
¼" SCH80, 13.7 mm x 3 mm	Straight	316
½" SCH80, 21.3 mm x 3.7 mm	Straight	316
½" SCH40, 21.3 mm x 2.7 mm	Straight	446



Various dimensions, such as the immersion length U for example, are variable values and are therefore indicated as items in the following dimensional drawings.

Variable dimensions:

Item	Description
L	Thermowell length (U+T)
TL	Thread length (length of engagement)
B	Thermowell base thickness: predefined, depends on thermowell version (see also the individual table data)
T	Length of lagging: variable or predefined, depends on thermowell version (see also the individual table data)
U	Immersion length: variable, depending on the configuration
D	Thermowell diameter

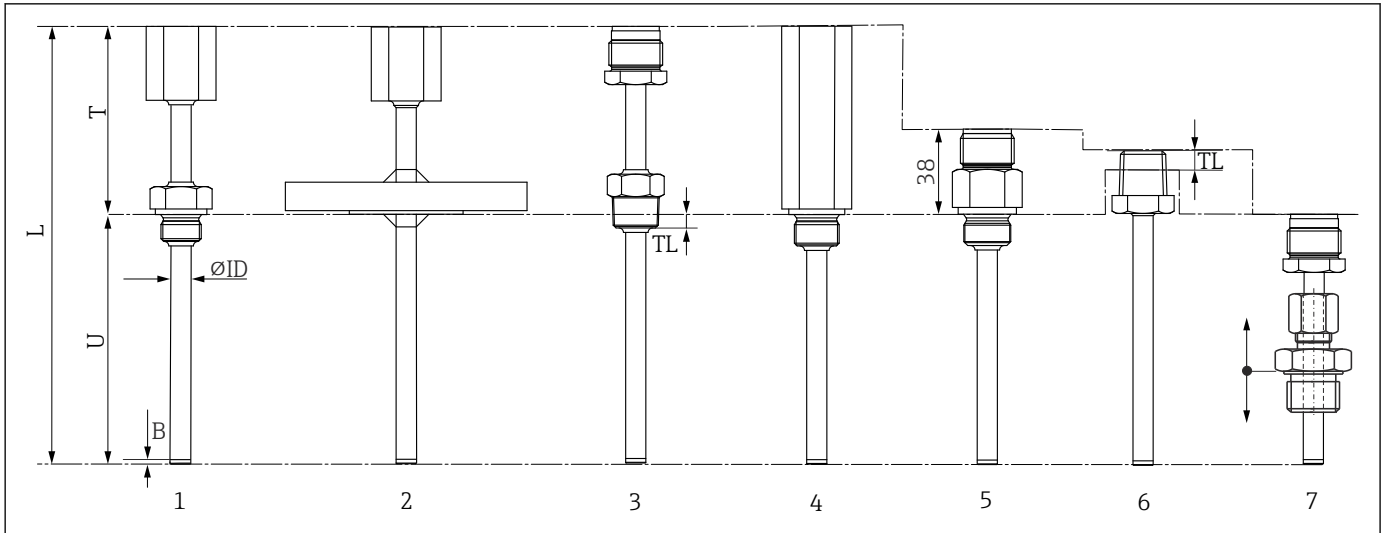

A0038643

- 1 Metric threaded process connection with extension (thermowell extension: option A)
- 2 Flanged process connection with extension (thermowell extension: option A)
- 3 NPT threaded process connection with extension (thermowell extension: option A)
- 4 Threaded process connection with hexagonal lagging (thermowell extension: option B)
- 5 Threaded process connection with hexagonal lagging (thermowell extension: option B)
- 6 Weld-in adapter without extension (thermowell extension: option 0)
- 7 Adjustable compression fitting without extension (thermowell extension: option 0)

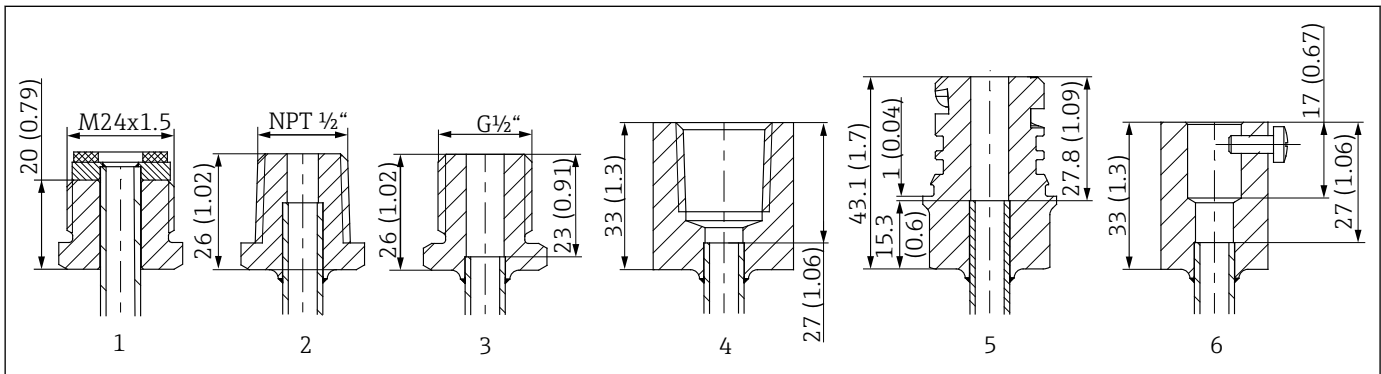

A0038649

- 6 Thermometer connection
- 1 Male thread M24x1.5
- 2 Male thread NPT 1/2"
- 3 Male thread G 1/2"
- 4 Female thread M20x1.5, NPT 1/2" and G 1/2"
- 5 Quick-fastening iTHERM QuickNeck
- 6 TA20L adapter

Possible combinations of the thermowell versions with the available process connections

Process connection and size	Thermowell diameter							
	9 x 1.25 mm	11 x 2 mm	12 x 2.5 mm	14 x 2 mm 316Ti	16 x 3.5 mm 316L	1/4" 316	1/2" 316	1/2" 446
Diameter tolerances								
Lower tolerance limit (mm)	0.0	0.0	0.0	0.0	0.0	-0.79	-0.79	-0.79
Upper tolerance limit (mm)	+0.1	+0.1	+0.1	+0.1	+0.1	+0.4	+0.4	+0.4
Thread								

Process connection and size	Thermowell diameter							
	9 x 1.25 mm	11 x 2 mm	12 x 2.5 mm	14 x 2 mm 316Ti	16 x 3.5 mm 316L	¼" 316	½" 316	½" 446
M18 x 1.5, 316L/316Ti	316L or 316Ti	316L or 316Ti	-	-	-	-	-	-
M20 x 1.5, 316L/316Ti	316L or 316Ti	316L or 316Ti	316Ti	316Ti	-	-	-	-
M27 x 2, 316L/316Ti	316L or 316Ti	316L or 316Ti	316Ti	316Ti	316L	-	-	-
M33 x 2, 316L/316Ti	316L or 316Ti	316L or 316Ti	316Ti	316Ti	316L	-	-	-
NPT ½", 316L/316Ti	316L or 316Ti	316L or 316Ti	316Ti	316Ti	-	316	-	-
NPT ¾", 316L/316Ti	316L or 316Ti	316L or 316Ti	316Ti	316Ti	316L	316	316	446
NPT 1", 316L/316Ti	316L or 316Ti	316L or 316Ti	316Ti	316Ti	316L	316	316	446
G 3/8, 316L/316Ti	316L or 316Ti	316L or 316Ti	316Ti	-	-	-	-	-
G ½", 316L/316Ti	316L or 316Ti	316L or 316Ti	316Ti	316Ti	-	-	-	-
G ¾", 316L/316Ti	316L or 316Ti	316L or 316Ti	316Ti	316Ti	316L	-	-	-
G 1", 316L/316Ti	316L or 316Ti	316L or 316Ti	316Ti	316Ti	316L	-	-	-
R ½", 316L/316Ti	316L or 316Ti	316L or 316Ti	316Ti	316Ti	-	-	-	-
R ¾", 316L/316Ti	316L or 316Ti	316L or 316Ti	316Ti	316Ti	316L	-	-	-
M20 x 1.55, 321	-	-	321	-	-	-	-	-
M27 x 2, 321	-	-	321	-	-	-	-	-
M33 x 2, 321	-	-	321	-	-	-	-	-
NPT ½", 321	-	-	321	-	-	-	-	-
G ½", 321	-	-	321	-	-	-	-	-
M20 x 1.5, AlloyC276	AlloyC276	AlloyC276	-	-	-	-	-	-
NPT ½", AlloyC276	AlloyC276	AlloyC276	-	-	-	-	-	-
G ½", AlloyC276	AlloyC276	AlloyC276	-	-	-	-	-	-
M20 x 1.5, AlloyC600	Alloy600	Alloy600	-	-	-	-	-	-
NPT ½", AlloyC600	Alloy600	Alloy600	-	-	-	-	-	-
G ½", AlloyC600	Alloy600	Alloy600	-	-	-	-	-	-
Weld-in adapter								
Cylindrical, D = 30 mm (1.18 in), 316L	316L, 316Ti, Alloy600, AlloyC276	-	-	-	-	-	-	-
Compression fitting								
NPT ½", 316L	316L, 316Ti, Alloy600, AlloyC276	316L or 316Ti	316Ti	316Ti	-	-	-	-

Process connection and size	Thermowell diameter							
	9 x 1.25 mm	11 x 2 mm	12 x 2.5 mm	14 x 2 mm 316Ti	16 x 3.5 mm 316L	¼" 316	½" 316	½" 446
G ½", 316L	316L, 316Ti, Alloy600, AlloyC276	316L or 316Ti	316Ti	316Ti	-	-	-	-
G 1", 316L	316L, 316Ti, Alloy600, AlloyC276	316L or 316Ti	316Ti	316Ti	-	-	-	-
With flange	316L	316L	316Ti	316Ti	316L	316	316	446
ANSI 1" 150 RF B16.5, 316L	316L	316L	316Ti	316Ti	316L	316	316	446
ANSI 1 ½" 150 RF B16.5, 316L	316L	316L	316Ti	316Ti	316L	316	316	446
ANSI 2" 150 RF B16.5, 316L	316L	316L	316Ti	316Ti	316L	316	316	446
ANSI 2" 300 RF B16.5, 316L	316L	316L	316Ti	316Ti	316L	316	316	446
DN15 PN40 B1 EN1092-1, 316L/316Ti	316L or 316Ti	316L or 316Ti	316Ti	316Ti	316L	316	-	-
DN15 PN40 C EN1092-1, 316L/316Ti	316L or 316Ti	316L or 316Ti	316Ti	316Ti	316L	316	-	-
DN25 PN20 B1 ISO7005-1, 316L/316Ti	316L or 316Ti	316L or 316Ti	316Ti	316Ti	316L	316	316	446
DN25 PN40 B1 EN1092-1, 316L/316Ti	316L or 316Ti	316L or 316Ti	316Ti	316Ti	316L	316	316	446
DN25 PN40 C EN1092-1, 316L/316Ti	316L or 316Ti	316L or 316Ti	316Ti	316Ti	316L	316	316	446
DN25 PN100 B2 EN1092-1, 316L/316Ti	316L or 316Ti	316L or 316Ti	316Ti	316Ti	316L	316	316	446
DN40 PN40 B1 EN1092-1, 316L/316Ti	316L or 316Ti	316L or 316Ti	316Ti	316Ti	316L	316	316	446
DN50 PN40 B1 EN1092-1, 316L/316Ti	316L or 316Ti	316L or 316Ti	316Ti	316Ti	316L	316	316	446
DN25 PN40 B1 EN1092-1, AlloyC276 > 316L	AlloyC279	AlloyC280	-	-	-	-	-	-
DN50 PN40 B1 EN1092-1, AlloyC276 > 316L	AlloyC280	AlloyC281	-	-	-	-	-	-
DN25 PN40 B1 EN1092-1, AlloyC600 > 316L	Alloy600	Alloy600	-	-	-	-	-	-
DN50 PN40 B1 EN1092-1, AlloyC600 > 316L	Alloy600	Alloy600	-	-	-	-	-	-
DN25 PN40 B1 EN1092-1, tantalum > 316Ti	-	316Ti + 12 mm	316Ti + 13 mm	-	-	-	-	-
DN50 PN40 B1 EN1092-1, tantalum > 316Ti	-	316Ti + 12 mm	316Ti + 13 mm	-	-	-	-	-
DN25 PN40 B1 EN1092-1, PTFE > 316Ti	-	316Ti + 15 mm	-	-	-	-	-	-
DN50 PN40 B1 EN1092-1, PTFE > 316Ti	-	316Ti + 15 mm	-	-	-	-	-	-

Weight Typically 0.2 to 7.5 kg (0.44 to 16.53 lbs) for standard options.

Material Thermowell and process connections.

The temperatures for continuous operation specified in the following table are only intended as reference values for use of the various materials in air and without any significant mechanical load. The maximum operating temperatures can be reduced considerably in cases where abnormal conditions such as high mechanical load occur or in aggressive media.

Please note that the maximum temperature also always depends on the temperature sensor used!

Material name	Short form	Recommended max. temperature for continuous use in air	Properties
AISI 316/1.4401	X5CrNiMo 17-12-2	650 °C (1202 °F) ¹⁾	<ul style="list-style-type: none"> ▪ Austenitic, stainless steel ▪ High corrosion resistance in general ▪ Particularly high corrosion-resistance in chlorinated and acidic, non-oxidizing atmospheres by adding molybdenum (e.g. phosphoric and sulfuric acids, acetic and tartaric acids with low concentration)
AISI 316L/1.4404 1.4435	X2CrNiMo17-12-2 X2CrNiMo18-14-3	650 °C (1202 °F) ¹⁾	<ul style="list-style-type: none"> ▪ Austenitic, stainless steel ▪ High corrosion resistance in general ▪ Particularly high corrosion-resistance in chlorinated and acidic, non-oxidizing atmospheres by adding molybdenum (e.g. phosphoric and sulfuric acids, acetic and tartaric acids with low concentration) ▪ Increased resistance to intergranular corrosion and pitting ▪ Compared to 1.4404, 1.4435 has even higher corrosion resistance and a lower delta ferrite content
AISI 316Ti/1.4571	X6CrNiMoTi17-12-2	700 °C (1292 °F) ¹⁾	<ul style="list-style-type: none"> ▪ Properties comparable with AISI316L ▪ Addition of titanium means increased resistance to intergranular corrosion even after welding ▪ Broad range of uses in the chemical, petrochemical and oil industries as well as in coal chemistry ▪ Can only be polished to a limited extent, titanium streaks can form
Alloy600/2.4816	NiCr15Fe	1 100 °C (2 012 °F)	<ul style="list-style-type: none"> ▪ A nickel/chromium alloy with very good resistance to aggressive, oxidizing and reducing atmospheres, even at high temperatures ▪ Resistance to corrosion caused by chlorine gases and chlorinated media as well as many oxidizing mineral and organic acids, sea water etc. ▪ Corrosion from ultrapure water ▪ Not to be used in sulfur-containing atmospheres
AlloyC276/2.4819	NiMo16Cr15W	1 100 °C (2 012 °F)	<ul style="list-style-type: none"> ▪ A nickel-based alloy with good resistance to oxidizing and reducing atmospheres, even at high temperatures ▪ Particularly resistant to chlorine gas and chloride as well as to many oxidizing mineral and organic acids
AISI 321/1.4541	X6CrNiTi18-10	815 °C (1 499 °F)	<ul style="list-style-type: none"> ▪ Austenitic, stainless steel ▪ High resistance to intergranular corrosion even after welding ▪ Good welding characteristics, suitable to all standard welding methods ▪ It is used in many sectors of the chemical industry, petrochemical, and pressurized vessels

Material name	Short form	Recommended max. temperature for continuous use in air	Properties
AISI 446/~1.4762/ ~1.4749	X10CrAl24 X18CrNi24	1 100 °C (2 012 °F)	<ul style="list-style-type: none"> ▪ A ferritic, heat resistant, high-chromium stainless steel ▪ Very high resistance to reducing sulphurous gases and salts with low content of oxygen ▪ Very good resistance to constant as well as cyclical thermal stress, to incineration ashcorrosion and to melts of copper, lead and tin ▪ Poorly resistant to gases containing nitrogen
Jacket			
PTFE (Teflon)	Polytetrafluorethylene	200 °C (392 °F)	<ul style="list-style-type: none"> ▪ Resistant to almost all chemicals ▪ High temperature-resistance
Tantalum	-	250 °C (482 °F)	<ul style="list-style-type: none"> ▪ With the exception of hydrofluoric acid, fluorine and fluorides, tantalum exhibits excellent resistance to most mineral acids and saline solutions ▪ Prone to oxidation and embrittlement at higher temperatures in air

- 1) Can be used to a limited extent up to 800 °C (1472 °F) for low mechanical loads and in non-corrosive media. Please contact your Endress+Hauser sales team for further information.

Process connections

Thread

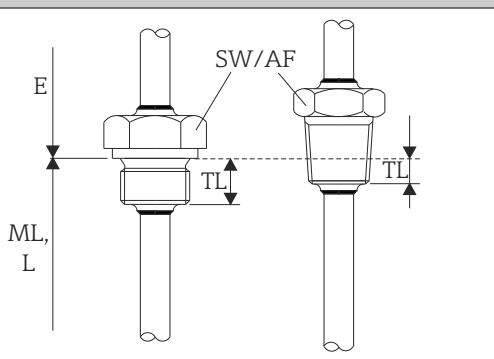
Threaded process connection Male thread	Version	Thread length TL	Wrench size	Max. process pressure	
 <p>7 Cylindrical (left side) and conical (right side) version</p>	M	M20x1.5	14 mm (0.55 in)	Maximum static process pressure for threaded process connection: <ul style="list-style-type: none"> ▪ 140 bar (2 031 psi) at +40 °C (+140 °F) ▪ 85 bar (1 233 psi) at +400 °C (+752 °F) 	
		M18x1.5	12 mm (0.47 in)		
		M27x2	16 mm (0.63 in)		
		M33x2	18 mm (0.71 in)		
	G ¹⁾	G ½" DIN / BSP	15 mm (0.6 in)		27 mm (1.06 in)
		G 1" DIN / BSP	18 mm (0.71 in)		41 mm (1.61 in)
		G ¾" BSP	15 mm (0.6 in)		32 mm (1.26 in)
		G 3/8"	12 mm (0.47 in)		24 mm (0.95 in)
	NPT	NPT ½"	8 mm (0.32 in)		22 mm (0.87 in)
		NPT ¾"	8.5 mm (0.33 in)		27 mm (1.06 in)
NPT 1"		10.2 mm (0.4 in)	41 mm (1.61 in)		

Threaded process connection Male thread	Version		Thread length TL	Wrench size	Max. process pressure
	R	R ¾"	8 mm (0.32 in)	27 mm (1.06 in)	
		R ½"		22 mm (0.87 in)	

1) DIN ISO 228 BSPP

 The 316L compression fittings can only be used once due to deformation. This applies to all the components of the compression fittings! A replacement compression fitting must be secured at another point (grooves in thermowell). PEEK compression fittings must never be used at a temperature that is lower than the temperature present when the compression fitting is secured. This is because the fitting would no longer be leak-tight as a result of heat contraction of the PEEK material.

For higher requirements: SWAGELOCK or similar fittings are urgently recommended.

Weld-in adapter

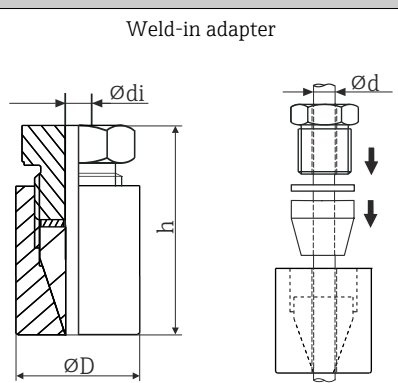
Type TK40 Weld-in adapter	Version	Dimensions			Technical properties
	Cylindrical	ødi	øD	h	
 <p style="text-align: right; font-size: small;">A0039132</p>	Ferrule material 316L Thread G½"	9.2 mm (0.36 in)	30 mm (1.18 in)	57 mm (2.24 in)	P _{max.} = 10 bar (145 psi), T _{max.} = +200 °C (+392 °F) for ELASTOSIL ferrule, tightening torque = 5 Nm

Compression fitting

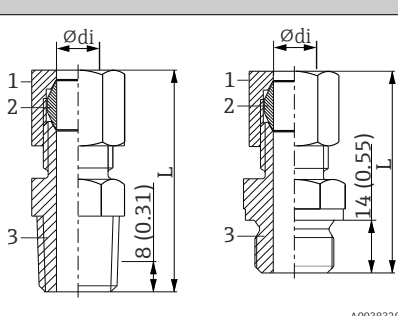
Type TK40	Version	Dimensions			Technical properties
		ødi	L	Wrench size	
 <p style="text-align: right; font-size: small;">A0038320</p> <p>1 Nut 2 Ferrule 3 Process connection</p>	NPT ½", ferrule material 316L G ½", ferrule material 316L	9 mm (0.35 in), minimum torque = 70 Nm	G½": 56 mm (2.2 in) ½" NPT: 60 mm (2.36 in)	G½": 27 mm (1.06 in) ½" NPT: 24 mm (0.95 in)	<ul style="list-style-type: none"> ▪ P_{max.} = 40 bar (104 psi) at T = +200 °C (+392 °F) for 316L ▪ P_{max.} = 25 bar (77 psi) at T = +400 °C (+752 °F) for 316L
		11 mm (0.43 in), minimum torque = 70 Nm			
		12 mm (0.47 in), minimum torque = 90 Nm			
		14 mm (0.55 in), minimum torque = 110 Nm			

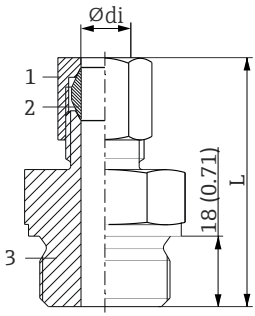
Type TK40	Version	Dimensions			Technical properties
		ϕ_{di}	L	Wrench size	
 <p>1 Nut 2 Ferrule 3 Process connection</p> <p>A0038344</p>	G 1", ferrule material 316L	12 mm (0.47 in), minimum torque = 90 Nm	64 mm (2.52 in)	41 mm (1.61 in)	<ul style="list-style-type: none"> ▪ $P_{max.} = 40$ bar (104 psi) at $T = +200$ °C (+392 °F) for 316L ▪ $P_{max.} = 25$ bar (77 psi) at $T = +400$ °C (+752 °F) for 316L
		14 mm (0.55 in), minimum torque = 110 Nm			

Flanges

i The flanges are supplied in stainless steel AISI 316L with material number 1.4404 or 1.4435. With regard to their stability-temperature property, the materials 1.4404 and 1.4435 are grouped together under 13E0 in DIN EN 1092-1 Tab.18 and under 023b in JIS B2220:2004 Tab. 5. The ASME flanges are grouped together under Tab. 2-2.2 in ASME B16.5-2013. Inches are converted into metric units (in - mm) using the factor 2.54. In the ASME standard, the metric data is rounded to 0 or 5.

Versions

- DIN flanges: German Standards Institute DIN 2527
- EN flanges: European standard DIN EN 1092-1:2002-06 and 2007
- ASME flanges: American Society of Mechanical Engineers ASME B16.5-2013
- JIS flanges: Japanese Industrial Standard B2220:2004

Geometry of sealing surfaces

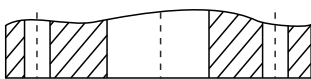
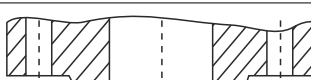
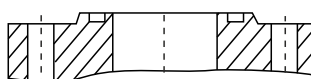
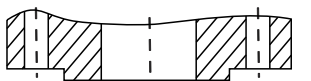
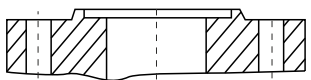
Flanges	Sealing surface	DIN 2526 ¹⁾		DIN EN 1092-1		
		Shape	Rz (μ m)	Shape	Rz (μ m)	Ra (μ m)
without raised face	 A0043514	A B	- 40 to 160	A ²⁾	12.5 to 50	3.2 to 12.5
with raised face	 A0043516	C D E	40 to 160 40 16	B1 ³⁾ B2	12.5 to 50 3.2 to 12.5	3.2 to 12.5 0.8 to 3.2
		Tongue	F	-	C	3.2 to 12.5
Groove	 A0043518	N		D		
Projection	 A0043519	V 13	-	E	12.5 to 50	3.2 to 12.5
Recess	 A0043520	R 13		F		

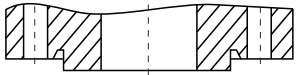
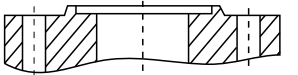
Flanges	Sealing surface	DIN 2526 ¹⁾		DIN EN 1092-1		
		Shape	Rz (µm)	Shape	Rz (µm)	Ra (µm)
Projection		V 14	for O-rings	H	3.2 to 12.5	3.2 to 12.5
Recess		R 14		G		

- 1) Contained in DIN 2527
- 2) Typically PN2.5 to PN40
- 3) Typically from PN63

Flanges according to the old DIN standard are compatible with the new DIN EN 1092-1 standard.
 Change in pressure ratings: Old DIN standards PN64 → DIN EN 1092-1 PN63.

Height of raised face ¹⁾

Standard	Flanges	Height of raised face f	Tolerance
DIN EN 1092-1:2002-06	all types	2 (0.08)	0 -1 (-0.04)
DIN EN 1092-1:2007	≤ DN 32	3 (0.12)	0 -2 (-0.08)
	> DN 32 to DN 250		
	> DN 250 to DN 500	4 (0.16)	0 -3 (-0.12)
	> DN 500	5 (0.19)	0 -4 (-0.16)
ASME B16.5 - 2013	≤ Class 300	1.6 (0.06)	±0.75 (±0.03)
	≥ Class 600	6.4 (0.25)	0.5 (0.02)
JIS B2220:2004	< DN 20	1.5 (0.06) 0	-
	> DN 20 to DN 50	2 (0.08) 0	
	> DN 50	3 (0.12) 0	

- 1) Dimensions in mm (in)

EN flanges (DIN EN 1092-1)

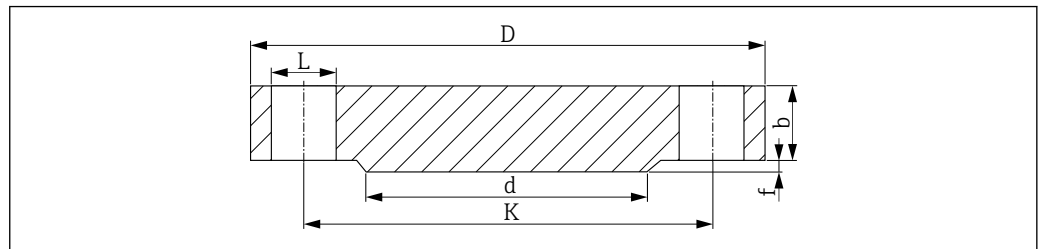

8 Raised face B1

- L Bore diameter
- d Diameter of raised face
- K Diameter of pitch circle
- D Flange diameter
- b Total flange thickness
- f Height of raised face (generally 2 mm (0.08 in))

PN16 ¹⁾

DN	D	b	K	d	L	approx. kg (lbs)
25	115 (4.53)	18 (0.71)	85 (3.35)	68 (2.68)	4xØ14 (0.55)	1.50 (3.31)
32	140 (5.51)	18 (0.71)	100 (3.94)	78 (3.07)	4xØ18 (0.71)	2.00 (4.41)
40	150 (5.91)	18 (0.71)	110 (4.33)	88 (3.46)	4xØ18 (0.71)	2.50 (5.51)
50	165 (6.5)	18 (0.71)	125 (4.92)	102 (4.02)	4xØ18 (0.71)	2.90 (6.39)
65	185 (7.28)	18 (0.71)	145 (5.71)	122 (4.80)	8xØ18 (0.71)	3.50 (7.72)
80	200 (7.87)	20 (0.79)	160 (6.30)	138 (5.43)	8xØ18 (0.71)	4.50 (9.92)
100	220 (8.66)	20 (0.79)	180 (7.09)	158 (6.22)	8xØ18 (0.71)	5.50 (12.13)
125	250 (9.84)	22 (0.87)	210 (8.27)	188 (7.40)	8xØ18 (0.71)	8.00 (17.64)
150	285 (11.2)	22 (0.87)	240 (9.45)	212 (8.35)	8xØ22 (0.87)	10.5 (23.15)
200	340 (13.4)	24 (0.94)	295 (11.6)	268 (10.6)	12xØ22 (0.87)	16.5 (36.38)
250	405 (15.9)	26 (1.02)	355 (14.0)	320 (12.6)	12xØ26 (1.02)	25.0 (55.13)
300	460 (18.1)	28 (1.10)	410 (16.1)	378 (14.9)	12xØ26 (1.02)	35.0 (77.18)

1) The dimensions in the following tables are in mm (in), unless otherwise specified.

PN25

DN	D	b	K	d	L	approx. kg (lbs)
25	115 (4.53)	18 (0.71)	85 (3.35)	68 (2.68)	4xØ14 (0.55)	1.50 (3.31)
32	140 (5.51)	18 (0.71)	100 (3.94)	78 (3.07)	4xØ18 (0.71)	2.00 (4.41)
40	150 (5.91)	18 (0.71)	110 (4.33)	88 (3.46)	4xØ18 (0.71)	2.50 (5.51)
50	165 (6.5)	20 (0.79)	125 (4.92)	102 (4.02)	4xØ18 (0.71)	3.00 (6.62)
65	185 (7.28)	22 (0.87)	145 (5.71)	122 (4.80)	8xØ18 (0.71)	4.50 (9.92)
80	200 (7.87)	24 (0.94)	160 (6.30)	138 (5.43)	8xØ18 (0.71)	5.50 (12.13)
100	235 (9.25)	24 (0.94)	190 (7.48)	162 (6.38)	8xØ22 (0.87)	7.50 (16.54)
125	270 (10.6)	26 (1.02)	220 (8.66)	188 (7.40)	8xØ26 (1.02)	11.0 (24.26)
150	300 (11.8)	28 (1.10)	250 (9.84)	218 (8.58)	8xØ26 (1.02)	14.5 (31.97)
200	360 (14.2)	30 (1.18)	310 (12.2)	278 (10.9)	12xØ26 (1.02)	22.5 (49.61)
250	425 (16.7)	32 (1.26)	370 (14.6)	335 (13.2)	12xØ30 (1.18)	33.5 (73.9)
300	485 (19.1)	34 (1.34)	430 (16.9)	395 (15.6)	16xØ30 (1.18)	46.5 (102.5)

PN40

DN	D	b	K	d	L	approx. kg (lbs)
25	115 (4.53)	18 (0.71)	85 (3.35)	68 (2.68)	4xØ14 (0.55)	1.50 (3.31)
32	140 (5.51)	18 (0.71)	100 (3.94)	78 (3.07)	4xØ18 (0.71)	2.00 (4.41)
40	150 (5.91)	18 (0.71)	110 (4.33)	88 (3.46)	4xØ18 (0.71)	2.50 (5.51)
50	165 (6.5)	20 (0.79)	125 (4.92)	102 (4.02)	4xØ18 (0.71)	3.00 (6.62)
65	185 (7.28)	22 (0.87)	145 (5.71)	122 (4.80)	8xØ18 (0.71)	4.50 (9.92)
80	200 (7.87)	24 (0.94)	160 (6.30)	138 (5.43)	8xØ18 (0.71)	5.50 (12.13)
100	235 (9.25)	24 (0.94)	190 (7.48)	162 (6.38)	8xØ22 (0.87)	7.50 (16.54)
125	270 (10.6)	26 (1.02)	220 (8.66)	188 (7.40)	8xØ26 (1.02)	11.0 (24.26)
150	300 (11.8)	28 (1.10)	250 (9.84)	218 (8.58)	8xØ26 (1.02)	14.5 (31.97)
200	375 (14.8)	36 (1.42)	320 (12.6)	285 (11.2)	12xØ30 (1.18)	29.0 (63.95)

DN	D	b	K	d	L	approx. kg (lbs)
250	450 (17.7)	38 (1.50)	385 (15.2)	345 (13.6)	12xØ33 (1.30)	44.5 (98.12)
300	515 (20.3)	42 (1.65)	450 (17.7)	410 (16.1)	16xØ33 (1.30)	64.0 (141.1)

PN63

DN	D	b	K	d	L	approx. kg (lbs)
25	140 (5.51)	24 (0.94)	100 (3.94)	68 (2.68)	4xØ18 (0.71)	2.50 (5.51)
32	155 (6.10)	24 (0.94)	110 (4.33)	78 (3.07)	4xØ22 (0.87)	3.50 (7.72)
40	170 (6.69)	26 (1.02)	125 (4.92)	88 (3.46)	4xØ22 (0.87)	4.50 (9.92)
50	180 (7.09)	26 (1.02)	135 (5.31)	102 (4.02)	4xØ22 (0.87)	5.00 (11.03)
65	205 (8.07)	26 (1.02)	160 (6.30)	122 (4.80)	8xØ22 (0.87)	6.00 (13.23)
80	215 (8.46)	28 (1.10)	170 (6.69)	138 (5.43)	8xØ22 (0.87)	7.50 (16.54)
100	250 (9.84)	30 (1.18)	200 (7.87)	162 (6.38)	8xØ26 (1.02)	10.5 (23.15)
125	295 (11.6)	34 (1.34)	240 (9.45)	188 (7.40)	8xØ30 (1.18)	16.5 (36.38)
150	345 (13.6)	36 (1.42)	280 (11.0)	218 (8.58)	8xØ33 (1.30)	24.5 (54.02)
200	415 (16.3)	42 (1.65)	345 (13.6)	285 (11.2)	12xØ36 (1.42)	40.5 (89.3)
250	470 (18.5)	46 (1.81)	400 (15.7)	345 (13.6)	12xØ36 (1.42)	58.0 (127.9)
300	530 (20.9)	52 (2.05)	460 (18.1)	410 (16.1)	16xØ36 (1.42)	83.5 (184.1)

PN100

DN	D	b	K	d	L	approx. kg (lbs)
25	140 (5.51)	24 (0.94)	100 (3.94)	68 (2.68)	4xØ18 (0.71)	2.50 (5.51)
32	155 (6.10)	24 (0.94)	110 (4.33)	78 (3.07)	4xØ22 (0.87)	3.50 (7.72)
40	170 (6.69)	26 (1.02)	125 (4.92)	88 (3.46)	4xØ22 (0.87)	4.50 (9.92)
50	195 (7.68)	28 (1.10)	145 (5.71)	102 (4.02)	4xØ26 (1.02)	6.00 (13.23)
65	220 (8.66)	30 (1.18)	170 (6.69)	122 (4.80)	8xØ26 (1.02)	8.00 (17.64)
80	230 (9.06)	32 (1.26)	180 (7.09)	138 (5.43)	8xØ26 (1.02)	9.50 (20.95)
100	265 (10.4)	36 (1.42)	210 (8.27)	162 (6.38)	8xØ30 (1.18)	14.0 (30.87)
125	315 (12.4)	40 (1.57)	250 (9.84)	188 (7.40)	8xØ33 (1.30)	22.5 (49.61)
150	355 (14.0)	44 (1.73)	290 (11.4)	218 (8.58)	12xØ33 (1.30)	30.5 (67.25)
200	430 (16.9)	52 (2.05)	360 (14.2)	285 (11.2)	12xØ36 (1.42)	54.5 (120.2)
250	505 (19.9)	60 (2.36)	430 (16.9)	345 (13.6)	12xØ39 (1.54)	87.5 (192.9)
300	585 (23.0)	68 (2.68)	500 (19.7)	410 (16.1)	16xØ42 (1.65)	131.5 (289.9)

ASME flanges (ASME B16.5-2013)

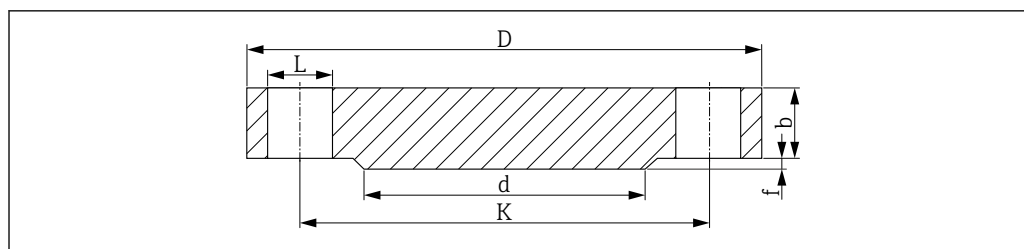

A0029175

9 Raised face RF

- L Bore diameter
d Diameter of raised face
K Diameter of pitch circle
D Flange diameter
b Total flange thickness
f Height of raised face, Class 150/300: 1.6 mm (0.06 in) or from Class 600: 6.4 mm (0.25 in)

Surface quality of raised face $Ra \leq 3.2$ to $6.3 \mu\text{m}$ (126 to $248 \mu\text{in}$).

Class 150¹⁾

DN	D	b	K	d	L	approx. kg (lbs)
1"	108.0 (4.25)	14.2 (0.56)	79.2 (3.12)	50.8 (2.00)	4x \emptyset 15.7 (0.62)	0.86 (1.9)
1¼"	117.3 (4.62)	15.7 (0.62)	88.9 (3.50)	63.5 (2.50)	4x \emptyset 15.7 (0.62)	1.17 (2.58)
1½"	127.0 (5.00)	17.5 (0.69)	98.6 (3.88)	73.2 (2.88)	4x \emptyset 15.7 (0.62)	1.53 (3.37)
2"	152.4 (6.00)	19.1 (0.75)	120.7 (4.75)	91.9 (3.62)	4x \emptyset 19.1 (0.75)	2.42 (5.34)
2½"	177.8 (7.00)	22.4 (0.88)	139.7 (5.50)	104.6 (4.12)	4x \emptyset 19.1 (0.75)	3.94 (8.69)
3"	190.5 (7.50)	23.9 (0.94)	152.4 (6.00)	127.0 (5.00)	4x \emptyset 19.1 (0.75)	4.93 (10.87)
3½"	215.9 (8.50)	23.9 (0.94)	177.8 (7.00)	139.7 (5.50)	8x \emptyset 19.1 (0.75)	6.17 (13.60)
4"	228.6 (9.00)	23.9 (0.94)	190.5 (7.50)	157.2 (6.19)	8x \emptyset 19.1 (0.75)	7.00 (15.44)
5"	254.0 (10.0)	23.9 (0.94)	215.9 (8.50)	185.7 (7.31)	8x \emptyset 22.4 (0.88)	8.63 (19.03)
6"	279.4 (11.0)	25.4 (1.00)	241.3 (9.50)	215.9 (8.50)	8x \emptyset 22.4 (0.88)	11.3 (24.92)
8"	342.9 (13.5)	28.4 (1.12)	298.5 (11.8)	269.7 (10.6)	8x \emptyset 22.4 (0.88)	19.6 (43.22)
10"	406.4 (16.0)	30.2 (1.19)	362.0 (14.3)	323.8 (12.7)	12x \emptyset 25.4 (1.00)	28.8 (63.50)

1) The dimensions in the following tables are in mm (in), unless otherwise specified.

Class 300

DN	D	b	K	d	L	approx. kg (lbs)
1"	124.0 (4.88)	17.5 (0.69)	88.9 (3.50)	50.8 (2.00)	4x \emptyset 19.1 (0.75)	1.39 (3.06)
1¼"	133.4 (5.25)	19.1 (0.75)	98.6 (3.88)	63.5 (2.50)	4x \emptyset 19.1 (0.75)	1.79 (3.95)
1½"	155.4 (6.12)	20.6 (0.81)	114.3 (4.50)	73.2 (2.88)	4x \emptyset 22.4 (0.88)	2.66 (5.87)
2"	165.1 (6.50)	22.4 (0.88)	127.0 (5.00)	91.9 (3.62)	8x \emptyset 19.1 (0.75)	3.18 (7.01)
2½"	190.5 (7.50)	25.4 (1.00)	149.4 (5.88)	104.6 (4.12)	8x \emptyset 22.4 (0.88)	4.85 (10.69)
3"	209.5 (8.25)	28.4 (1.12)	168.1 (6.62)	127.0 (5.00)	8x \emptyset 22.4 (0.88)	6.81 (15.02)
3½"	228.6 (9.00)	30.2 (1.19)	184.2 (7.25)	139.7 (5.50)	8x \emptyset 22.4 (0.88)	8.71 (19.21)
4"	254.0 (10.0)	31.8 (1.25)	200.2 (7.88)	157.2 (6.19)	8x \emptyset 22.4 (0.88)	11.5 (25.36)
5"	279.4 (11.0)	35.1 (1.38)	235.0 (9.25)	185.7 (7.31)	8x \emptyset 22.4 (0.88)	15.6 (34.4)
6"	317.5 (12.5)	36.6 (1.44)	269.7 (10.6)	215.9 (8.50)	12x \emptyset 22.4 (0.88)	20.9 (46.08)
8"	381.0 (15.0)	41.1 (1.62)	330.2 (13.0)	269.7 (10.6)	12x \emptyset 25.4 (1.00)	34.3 (75.63)
10"	444.5 (17.5)	47.8 (1.88)	387.4 (15.3)	323.8 (12.7)	16x \emptyset 28.4 (1.12)	53.3 (117.5)

Class 600

DN	D	b	K	d	L	approx. kg (lbs)
1"	124.0 (4.88)	17.5 (0.69)	88.9 (3.50)	50.8 (2.00)	4xØ19.1 (0.75)	1.60 (3.53)
1¼"	133.4 (5.25)	20.6 (0.81)	98.6 (3.88)	63.5 (2.50)	4xØ19.1 (0.75)	2.23 (4.92)
1½"	155.4 (6.12)	22.4 (0.88)	114.3 (4.50)	73.2 (2.88)	4xØ22.4 (0.88)	3.25 (7.17)
2"	165.1 (6.50)	25.4 (1.00)	127.0 (5.00)	91.9 (3.62)	8xØ19.1 (0.75)	4.15 (9.15)
2½"	190.5 (7.50)	28.4 (1.12)	149.4 (5.88)	104.6 (4.12)	8xØ22.4 (0.88)	6.13 (13.52)
3"	209.5 (8.25)	31.8 (1.25)	168.1 (6.62)	127.0 (5.00)	8xØ22.4 (0.88)	8.44 (18.61)
3½"	228.6 (9.00)	35.1 (1.38)	184.2 (7.25)	139.7 (5.50)	8xØ25.4 (1.00)	11.0 (24.26)
4"	273.1 (10.8)	38.1 (1.50)	215.9 (8.50)	157.2 (6.19)	8xØ25.4 (1.00)	17.3 (38.15)
5"	330.2 (13.0)	44.5 (1.75)	266.7 (10.5)	185.7 (7.31)	8xØ28.4 (1.12)	29.4 (64.83)
6"	355.6 (14.0)	47.8 (1.88)	292.1 (11.5)	215.9 (8.50)	12xØ28.4 (1.12)	36.1 (79.6)
8"	419.1 (16.5)	55.6 (2.19)	349.3 (13.8)	269.7 (10.6)	12xØ31.8 (1.25)	58.9 (129.9)
10"	508.0 (20.0)	63.5 (2.50)	431.8 (17.0)	323.8 (12.7)	16xØ35.1 (1.38)	97.5 (214.9)

Class 900

DN	D	b	K	d	L	approx. kg (lbs)
1"	149.4 (5.88)	28.4 (1.12)	101.6 (4.0)	50.8 (2.00)	4xØ25.4 (1.00)	3.57 (7.87)
1¼"	158.8 (6.25)	28.4 (1.12)	111.3 (4.38)	63.5 (2.50)	4xØ25.4 (1.00)	4.14 (9.13)
1½"	177.8 (7.0)	31.8 (1.25)	124.0 (4.88)	73.2 (2.88)	4xØ28.4 (1.12)	5.75 (12.68)
2"	215.9 (8.50)	38.1 (1.50)	165.1 (6.50)	91.9 (3.62)	8xØ25.4 (1.00)	10.1 (22.27)
2½"	244.4 (9.62)	41.1 (1.62)	190.5 (7.50)	104.6 (4.12)	8xØ28.4 (1.12)	14.0 (30.87)
3"	241.3 (9.50)	38.1 (1.50)	190.5 (7.50)	127.0 (5.00)	8xØ25.4 (1.00)	13.1 (28.89)
4"	292.1 (11.50)	44.5 (1.75)	235.0 (9.25)	157.2 (6.19)	8xØ31.8 (1.25)	26.9 (59.31)
5"	349.3 (13.8)	50.8 (2.0)	279.4 (11.0)	185.7 (7.31)	8xØ35.1 (1.38)	36.5 (80.48)
6"	381.0 (15.0)	55.6 (2.19)	317.5 (12.5)	215.9 (8.50)	12xØ31.8 (1.25)	47.4 (104.5)
8"	469.9 (18.5)	63.5 (2.50)	393.7 (15.5)	269.7 (10.6)	12xØ38.1 (1.50)	82.5 (181.9)
10"	546.1 (21.50)	69.9 (2.75)	469.0 (18.5)	323.8 (12.7)	16xØ38.1 (1.50)	122 (269.0)

Class 1500

DN	D	b	K	d	L	approx. kg (lbs)
1"	149.4 (5.88)	28.4 (1.12)	101.6 (4.0)	50.8 (2.00)	4xØ25.4 (1.00)	3.57 (7.87)
1¼"	158.8 (6.25)	28.4 (1.12)	111.3 (4.38)	63.5 (2.50)	4xØ25.4 (1.00)	4.14 (9.13)
1½"	177.8 (7.0)	31.8 (1.25)	124.0 (4.88)	73.2 (2.88)	4xØ28.4 (1.12)	5.75 (12.68)
2"	215.9 (8.50)	38.1 (1.50)	165.1 (6.50)	91.9 (3.62)	8xØ25.4 (1.00)	10.1 (22.27)
2½"	244.4 (9.62)	41.1 (1.62)	190.5 (7.50)	104.6 (4.12)	8xØ28.4 (1.12)	14.0 (30.87)
3"	266.7 (10.5)	47.8 (1.88)	203.2 (8.00)	127.0 (5.00)	8xØ31.8 (1.25)	19.1 (42.12)
4"	311.2 (12.3)	53.8 (2.12)	241.3 (9.50)	157.2 (6.19)	8xØ35.1 (1.38)	29.9 (65.93)
5"	374.7 (14.8)	73.2 (2.88)	292.1 (11.5)	185.7 (7.31)	8xØ41.1 (1.62)	58.4 (128.8)
6"	393.7 (15.50)	82.6 (3.25)	317.5 (12.5)	215.9 (8.50)	12xØ38.1 (1.50)	71.8 (158.3)
8"	482.6 (19.0)	91.9 (3.62)	393.7 (15.5)	269.7 (10.6)	12xØ44.5 (1.75)	122 (269.0)
10"	584.2 (23.0)	108.0 (4.25)	482.6 (19.0)	323.8 (12.7)	12xØ50.8 (2.00)	210 (463.0)

Thermowell material, nickel-based, with flange

If the thermowell materials Alloy600 and Alloy C276 are combined with a flange process connection, only the raised face and not the complete flange is made of the alloy for cost reasons. This is welded onto a flange with the parent material 316L. Identified in the order code by the material designation Alloy600 > 316L or Alloy C276 > 316L.

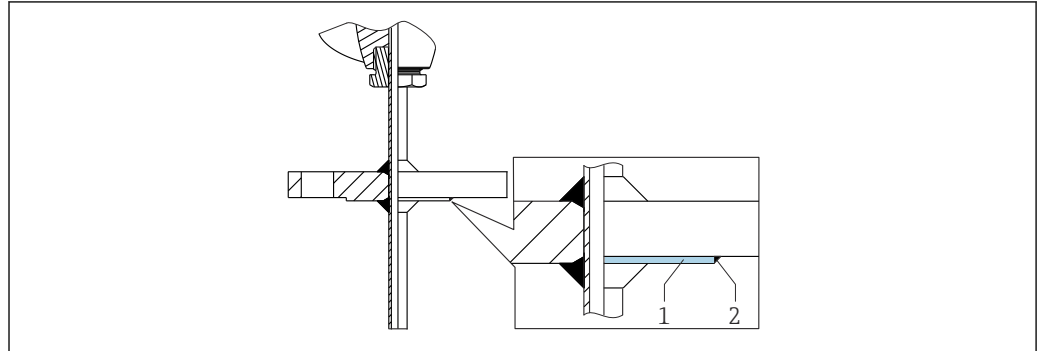

A0049523

- 1 Raised face
2 Weld

Tip shape

The thermal response time, the reduction of the flow cross-section and the mechanical load that occurs in the process are the criteria that matter when selecting the shape of the tip. Advantages of using reduced or tapered thermowell tips:

- A smaller tip shape has less impact on the flow characteristics of the pipe carrying the medium.
- The flow characteristics are optimized, thereby increasing the stability of the thermowell.
- Endress+Hauser offers users a range of thermowell tips to meet every requirement:
 - Reduced tip with $\phi 4.3$ mm (0.17 in) and $\phi 5.3$ mm (0.21 in): walls of lower thickness significantly reduce the response times of the overall measuring point.
 - Tapered tip with $\phi 6.6$ mm (0.26 in) and reduced tip with $\phi 9$ mm (0.35 in): walls of greater thickness are particularly well suited to applications with a higher degree of mechanical load or wear (e.g. pitting, abrasion).

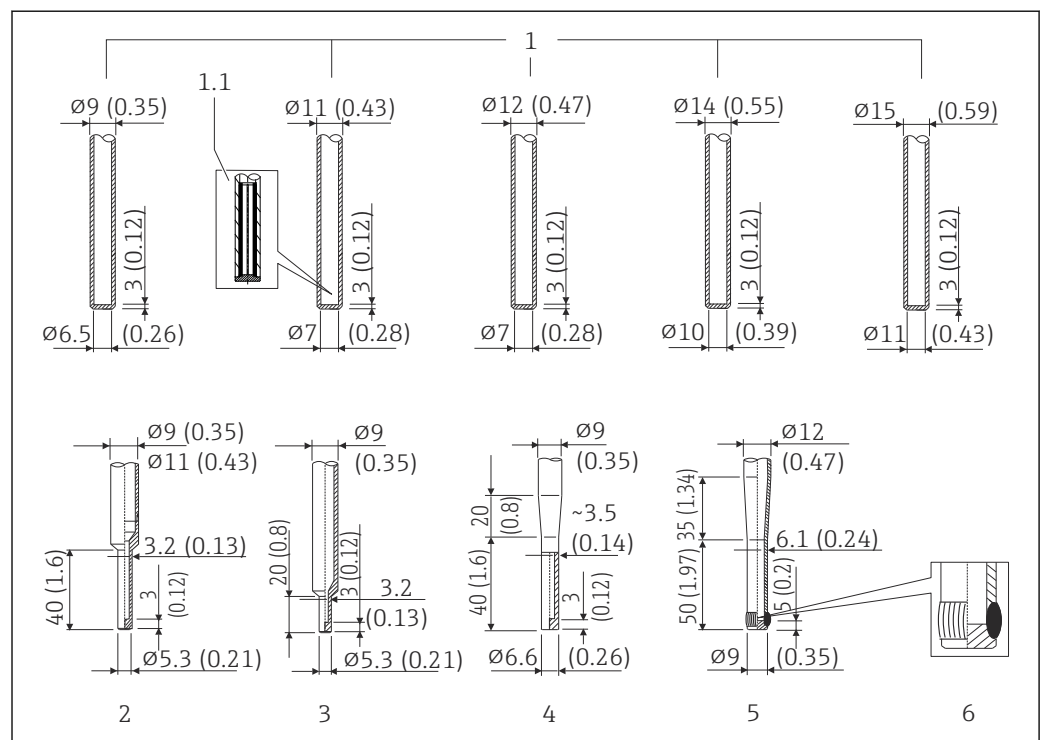

A0019347

- 10 Available thermowell tips (reduced, straight or tapered). Maximum surface roughness $R_a \leq 0.76 \mu\text{m}$ (30 μin). Bottom thickness = 3 mm (0.12 in) for straight version, except bottom thickness for schedule (SCH) straight versions = 4 mm (0.16 in)

Item No.	Tip shape	Insert diameter
1	Straight	6 mm (0.24 in)
1.1	Tip assembly detail: fast response time design is available for $\phi 11$ mm (0.43 in) and $\phi 12$ mm (0.47 in) as an option. The gap between the insert and thermowell is filled with a stable heat transfer material.	
2	Reduced, $U \geq 70$ mm (2.76 in)	3 mm (0.12 in)
3	Reduced, $U \geq 50$ mm (1.97 in) ¹⁾	3 mm (0.12 in)
4	Tapered, $U \geq 70$ mm (2.76 in) ¹⁾	3 mm (0.12 in)
5	Tapered DIN43772-3G, $U \geq 90$ mm (3.54 in) ^{1) 2)}	6 mm (0.24 in)
6	Welded tip, weld quality according to EN ISO 5817 - quality class B	

- 1) Not with the following materials: Alloy C276, Alloy600, 321, 316 and 446
2) Tip assembly detail: fast response time design is available as an option. The gap between the insert and thermowell is filled with a stable heat transfer material.



It is possible to check the mechanical loading capacity as a function of the installation and process conditions online in the TW Sizing Module for thermowells in the Endress+Hauser Applicator software. See 'Accessories' section.

Surface roughness

Values for wetted surfaces:

Standard surface	$R_a \leq 0.76 \mu\text{m}$ (0.03 μin)
------------------	--

Certificates and approvals

CRN approval

The CRN approval is only available for certain thermowell versions. These versions are identified and displayed accordingly during the configuration of the device.

Detailed ordering information is available for your nearest sales organization www.addresses.endress.com or in the Download Area under www.endress.com :

1. Select the country
2. Select Downloads
3. In the search area: select Approvals/approval type
4. Enter the product code or device
5. Start the search

Other standards and guidelines

DIN 43772: Thermowells

Service

- Free from oil and grease for O₂ applications, optional
- PWIS-free (PWIS = paint-wetting impairment substances as per DIL0301), optional

Material certification

The material certificate 3.1 (according to standard EN 10204) can be requested separately. The "short form" certificate includes a simplified declaration with no enclosures of documents related to the materials used in the construction of the single sensor and guarantees the traceability of the materials through the identification number of the thermometer. The data related to the origin of the materials can subsequently be requested by the client if necessary.

Thermowell testing

Thermowell pressure tests are carried out in accordance with the specifications in DIN 43772. Thermowells with tapered or reduced tips that do not comply with this standard are tested using the pressure rating of equivalent straight thermowells. In addition, sensors for use in hazardous areas are always subjected to an equivalent pressure during testing. Tests according to other specifications can be carried out on request. The liquid penetration test verifies that there are no cracks in the welded seams of the thermowell.

Helium leak test as per EN 1779	Leak test for thermowells, welding seams and threaded joints. Depending on its design and size, the thermowell can be subjected to helium gas internally or externally. With inspection certificate.
Hydrostatic pressure test	External and internal pressure test with maximum 400 bar (5801 psi) to check the pressure resistance and leak-tightness of thermowells, without flanges. Internal pressure test only possible for thermowells with an internal thread (type 1). With inspection certificate.
Positive material identification (PMI) test	Nondestructive material identification and testing of welded joints. Material identification check, X-ray fluorescence analysis. With inspection certificate.
Load capacity calculation for the thermowell	In accordance with DIN 43772 or ASME PTC19.3, with calculation certificate
Dye penetration test as per ASME V and EN571-1	Suitable for checking welding seam surfaces, e.g. detection of small cracks, etc. With inspection certificate.
Bore concentricity test for thermowells	With inspection certificate.
Radiographic test as per ASME V, VIII, TW welding	With inspection certificate.

Ordering information

Detailed ordering information is available for your nearest sales organization www.addresses.endress.com or in the Product Configurator under www.endress.com :

1. Click Corporate
2. Select the country
3. Click Products
4. Select the product using the filters and search field
5. Open the product page

The Configuration button to the right of the product image opens the Product Configurator.



Product Configurator - the tool for individual product configuration

- Up-to-the-minute configuration data
- Depending on the device: Direct input of measuring point-specific information such as measuring range or operating language
- Automatic verification of exclusion criteria
- Automatic creation of the order code and its breakdown in PDF or Excel output format
- Ability to order directly in the Endress+Hauser Online Shop

Accessories

Various accessories, which can be ordered with the device or subsequently from Endress+Hauser, are available for the device. Detailed information on the order code in question is available from your local Endress+Hauser sales center or on the product page of the Endress+Hauser website: www.endress.com.

Device-specific accessories

Accessories	Description
<p>Welding boss with sealing taper (metal - metal)</p> <p>A0006621</p> <p>A0018236</p>	<p>Welding boss for G$\frac{1}{2}$" and M12x1 thread Metal-sealing; conical Material of wetted parts: 316L/1.4435 Max. process pressure: 16 bar (232 PSI)</p> <p>Order number:</p> <ul style="list-style-type: none"> 60021387 (G$\frac{1}{2}$") 71190468 (M12x1)
<p>Dummy plug</p> <p>A0045726</p> <p>1 Size across flats SW22</p>	<p>Dummy plug for G$\frac{1}{2}$" or M12x1 conical metal-sealing welding boss Material: SS 316L/1.4435</p> <p>Order number:</p> <ul style="list-style-type: none"> 60022519 (G$\frac{1}{2}$") 60021194 (M12x1)

i Maximum process pressure for weld-in adapters:



- 25 bar (362 PSI) at maximum 150 °C (302 °F)
- 40 bar (580 PSI) at maximum 100 °C (212 °F)



For more information on the weld-in adapters FTL20/31/33, FTL50, see the Technical Information (TI00426F/00).

Service-specific accessories

Accessories	Description
Applicator	<p>Software for selecting and sizing Endress+Hauser measuring devices:</p> <ul style="list-style-type: none"> Calculation of all the necessary data for identifying the optimum measuring device: e.g. pressure loss, accuracy or process connections. Graphic illustration of the calculation results <p>Administration, documentation and access to all project-related data and parameters over the entire life cycle of a project.</p> <p>Applicator is available: Via the Internet: https://portal.endress.com/webapp/applicator</p>

Accessories	Description
Configurator	<p>Product Configurator - the tool for individual product configuration</p> <ul style="list-style-type: none"> ▪ Up-to-the-minute configuration data ▪ Depending on the device: Direct input of measuring point-specific information such as measuring range or operating language ▪ Automatic verification of exclusion criteria ▪ Automatic creation of the order code and its breakdown in PDF or Excel output format ▪ Ability to order directly in the Endress+Hauser Online Shop <p>The Configurator is available on the Endress+Hauser website at: www.endress.com -> Click "Corporate" -> Select your country -> Click "Products" -> Select the product using the filters and search field -> Open product page -> The "Configure" button to the right of the product image opens the Product Configurator.</p>
DeviceCare SFE100	<p>Configuration tool for devices via fieldbus protocols and Endress+Hauser service protocols. DeviceCare is the tool developed by Endress+Hauser for the configuration of Endress+Hauser devices. All smart devices in a plant can be configured via a point-to-point or point-to-bus connection. The user-friendly menus enable transparent and intuitive access to the field devices.</p> <p> For details, see Operating Instructions BA00027S</p>
FieldCare SFE500	<p>FDT-based plant asset management tool from Endress+Hauser. It can configure all smart field units in your system and helps you manage them. By using the status information, it is also a simple but effective way of checking their status and condition.</p> <p> For details, see Operating Instructions BA00027S and BA00065S</p>
Accessories	Description
W@M	<p>Life cycle management for your plant W@M offers assistance with a wide range of software applications over the entire process: from planning and procurement to the installation, commissioning and operation of the measuring devices. All the relevant information is available for every measuring device over the entire life cycle, such as the device status, device-specific documentation, spare parts etc. The application already contains the data of your Endress+Hauser device. Endress+Hauser also takes care of maintaining and updating the data records.</p> <p>W@M is available: Via the Internet: www.endress.com/lifecyclemanagement</p>

Documentation

Operating Instructions: Thermowells for thermometers in industrial applications (BA02041T)

Technical Information:

- Modular RTD or TC Thermometer:
 - iTHERM TM131 (TI01373T)
 - iTHERM TM121 (TI01455T)
- Insert:
 - iTHERM TS111 (TI01014T) and iTHERM TS211 (TI01411T)



71522631

www.addresses.endress.com
